



MODULAR REMOTE LOW-SIDE & SPLIT AIR COOLED FLAKE ICE MACHINES

## Model 4000 Rapid Freeze



Model 4000-RL

Based on	Remote/ Split	
70°F (21°C) Water	Lbs.	Kg.
90°F (32°C) Air		
4000-RL	4000	1816
Ice Quality	100 %	

The Rapid Freeze Model 4000 ice flaker features unexcelled quality, reliability, and long life. It is durable, energy efficient and provides a high degree of flexibility to a wide diversity of commercial and industrial applications.

### UNEXCELLED ENERGY EFFICIENCY

Howe's Rapid Freeze Flaker utilizes an innovative extended surface evaporator design and unique material combination to offer significantly superior heat transfer characteristics over most ice machines in the industry. As a proven innovator for over 50 years, Howe brings a distinctive blend of technology and engineering expertise to enable Howe Flakers to operate at considerably lower cost than popular granular style flake ice machines.

### REMARKABLE LONGEVITY

The rugged "Open Style" Rapid Freeze evaporator design allows ice to be harvested by gravity, avoiding the punishing bearing loads that granular style flakers experience during harvest by an extrusion process. Howe's approximate 50% lighter bearing load enables Rapid Freeze Flake Ice Machines to frequently last three to four times longer than competitive machines.

### EXCEPTIONAL QUALITY ICE

Rapid Freeze units produce the "Authentic" 100% dry, sub-cooled flake ice that contains approximately four (4) times more surface area than many competitive flake ice machines. When compared to granular style flake ice machines whose production is only partially frozen (between 65% and 70% ice quality), Howe Flake Ice offers significantly greater cooling capacity, and lasts up to 20% longer.

### RELIABLE ICE PRODUCTION CAPACITY

Howe Rapid Freeze Flake Ice Machines are some of the only flakers which voluntarily base model numbers on daily capacities using ARI conditions of 70°F water and 90°F air temperatures (21°C/ 32°C), de-rated for 100% ice. Compared to comparable model granular style flake ice machines, it is not uncommon for Howe Flakers to produce approximately twice as much ice as competitive units at ARI conditions.

### WARRANTY PROTECTION

 See complete warranty for details.

- 25 year evaporator warranty.
- 10 year ice blade warranty.
- 2 year parts warranty.
- 5 year compressor warranty (Optional).

Ice flakers are designed for ambient temperatures between 90°F & 60°F. When installing in ambient temperatures below 60°F, a Low Ambient Kit is recommended.

The Low Ambient Kit consists of 3 replaceable heating elements to prevent ice from forming on the bottom of the machine.



Available as factory option when ordering new equipment only.

### Howe Modular Bins

Bin Models	Dimensions inches / cm.			Mobile Poly Carts	Approx. Storage Capacity	Exterior Finish	Interior Finish	Shipping Weight lbs. / kg.
	W	D*	H					
CP2500	60 / 92	36 / 92	92 / 234	2	2500 lbs	SS	Poly	690 / 314
C-3200	90 / 229	36 / 92	101 / 257	3	3200 lbs	SS	SS	1570 / 713
380-SS	72 / 183	48 / 122	76 / 193	-	3800 lbs	SS	SS	800 / 364
490-SS	72 / 183	48 / 122	96 / 244	-	4900 lbs	SS	SS	980 / 445



CP3200 Mobile Express Bin



# Model 4000 RAPID FREEZE

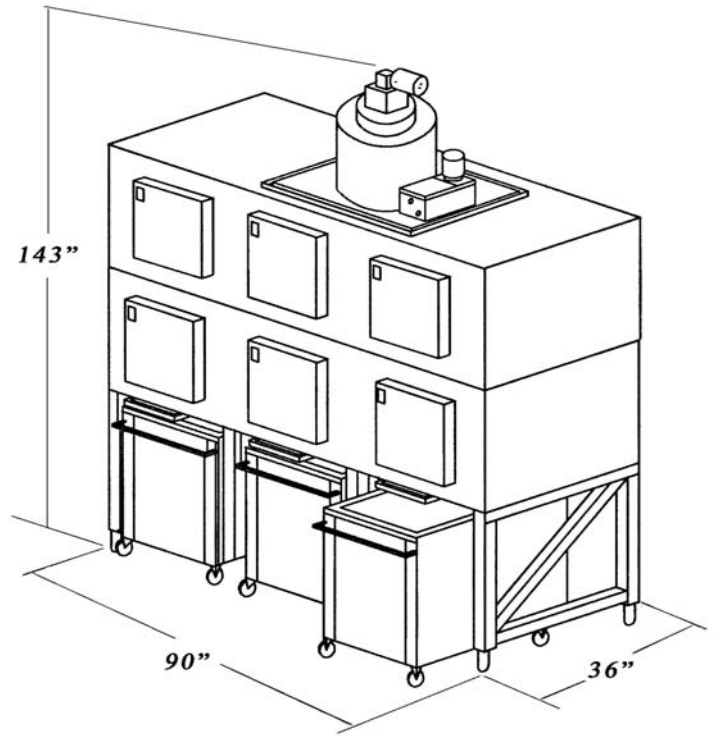
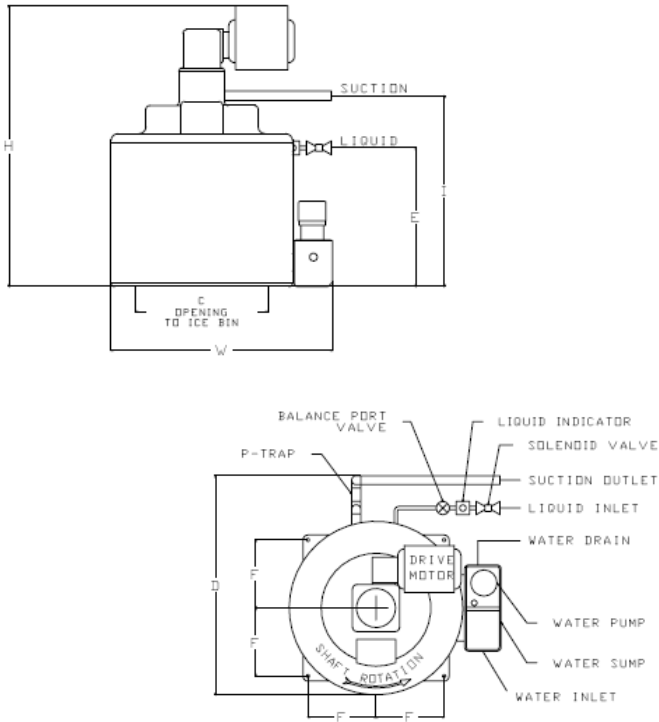

4000-RL on CP3200

MODEL No.	DIMENSIONS (INCHES)					Connection Sizes (ODS)		
	C	E	F	G	I	SUCTION	LIQUID	WATER
4000-RL	19	20	10-1/4	17-1/2	27-1/2	1-3/8	1/2	3/8

## ICE FLAKER SPECIFICATIONS

Model Number	Capacity per 24 Hrs. @ 70°/90°F (21°/32°C)	KWH/100 lbs. Ice @ 70°/90°F (21°/32°C)	Drive Motor 208-230/1/60		Water Pump	Compressor 230/1/60		Cond. Fan 230/1/60	Total Approx.	Min. Circuit	Max. Fuse
			H.P.	F.L.A.		F.L.A.	R.L.A.				
4000-RL	4000 Lbs.	.49	1/3	3.2	.75	-	-	-	3.95	5	15
4000-RLH*	4000 Lbs.	3.1	1/3	3.2	.75	25.3	161	2.7	31.95	35	50

MODEL	DIMENSIONS (INCHES)			SHIPPING WEIGHT	WATER - G.P.M.		APPROX. OPERATING CHARGE R-404A	REFRIG. REQUIRED @ -5°F EVAP.
	W	D	H		lbs	FLAKER		
4000-RL	32	33	40 1/2	700	.35	—	15	34,100

## CONDENSING UNIT SPECIFICATIONS

Model	Type	Refrig.	Power	Dimensions						Electrical Data			Shipping Weight	
				Inches			Centimeters			RLA	MCA	MOP	Lbs.	Kg.
				W	D	H	W	D	H					
4000-RHS	A/C	R-404A	208-	51 3/4	36 3/4	39 1/4	131.44	93.35	99.70	25.3	34.4	50.0	904	410
		R-22	230/3/60	51 3/4	36 3/4	39 1/4	131.44	93.35	99.70	24.0	32.7	50.0	904	410

### Ice Flaker Operating Parameters

NSF, ETL Approved.

	Minimum*	Optimum	Maximum
Ambient Temperature	60°F (10°C)	90°F (32°C)	100°F (38°C)
Water Temperature	45°F (8°C)	70°F (21°C)	90°F (32°C)
Water Pressure	15 PSI	18-20 PSI	60 PSI

\* without low ambient kit

