

Rapid Freeze

1000-RLE

for Remote Refrigeration Systems

COOL SOLUTIONS SINCE 1912

HOWE Proven. Best Choice.™

Howe's versatile Rapid Freeze Flake Ice Machines set the standard for energy efficiency, water conservation and longer, trouble-free operating life. Our reliable ice flakers are engineered to deliver exceptional ice quality that keeps food cooler and fresher, longer, at reduced operating expense.

From food processing and distribution, to supermarket and retail applications, Howe has an energy-efficient Rapid Freeze solution to meet your needs.

PROVEN ENERGY EFFICIENCY

Innovative engineering, rugged construction deliver exceptional heat transfer. Requires significantly less energy per pound. Substantially lower operating/maintenance requirements. Optimized water usage.

EXCEPTIONAL ICE QUALITY

True, 100% dry, sub-cooled flake ice contains 4 times more surface area for significantly better cooling – up to 20% longer. Drier ice draws heat away quickly and evenly. Process uses less energy with virtually zero water loss.

LONGER, TROUBLE-FREE OPERATING LIFE

Innovative evaporator design utilizes gravity for 50% lighter bearing load. Operates, trouble-free, 3 - 4 times longer than competitive machines. Fewer maintenance/service issues.

STANDARD PACKAGE INCLUDES:

- Pre-wired, integrated control panel
- Photo eye ice level control system
- Low water level switch
- TXV Valve (expansion valve) (for virtually any available refrigerant)
- Solenoid Valve
- EPR Valve
- Suction line heat exchanger

AVAILABLE OPTIONS/ACCESSORIES

- Clock timer
- Water filter system
- Salt dosing kit
- Ice storage bins (many options available)



1000-RLE shown on CP1500 Mobile Express bin system. Storage bin system sold separately.



MADE IN USA!

ICE CAPACITIES

		WATER TEMP °F		
		50°	70°	90°
AIR TEMP °F	70°	1320	1136	1032
	80°	1264	1088	992
	90°	1160	1014	920

ICE QUALITY & HARDNESS

Ice of higher quality has more cooling capacity per pound than that of lesser quality ice.

ICE QUALITY %*	IHAF**	KWH/100 LBS
93.3	.933	2.78

* Ice Quality expressed as a percentage of cooling capacity of 100% 32°F ice.

**Ice Hardness Adjustment Factor used to correct kWh/100lb for ice quality.
All data given at 90°F air / 70°F water.

1000-RLE

for Remote Refrigeration Systems

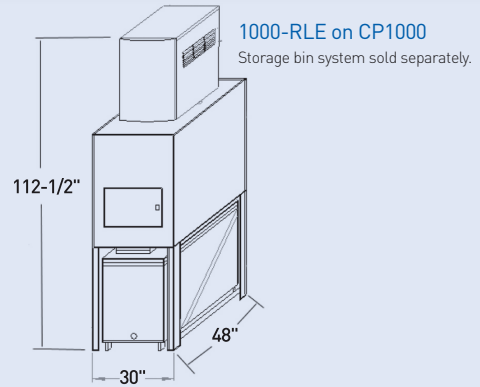
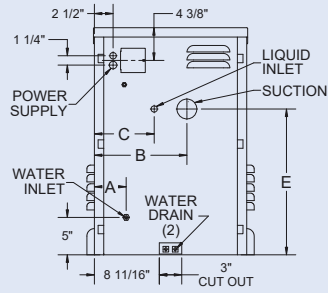
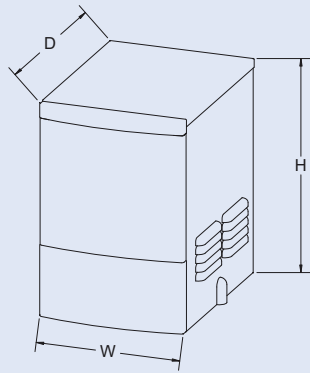

MODEL	DIMENSIONS (INCHES/CM)				POWER SUPPLY	SUCTION	LIQUID	DRAIN	WATER SUPPLY
	A	B	C	E					
1000-RLE	4-1/4	12-3/16	7-11/16	19-1/2	1/2 K.O.	7/8 ODS	3/8 ODS	1/2 ID HOSE	3/8 COMP.
	10.78	30.96	19.53	49.53					

ICE FLAKER

MODEL	CAPACITY/ 24 HRS* LBS/KG	KWH/ 100 LBS* 45.4 KG	WATER USAGE/ 100 LBS OF ICE GALS/LITERS	WATER GPM LPM	DRIVE MOTOR 208-230/1/60		WATER PUMP FLA	TOTAL APPROX. RLA	MIN. CIRCUIT AMPS	MAX. FUSE AMPS
					HP	FLA				
1000-RLE	1,014 LBS	2.78 ¹	12.0	.10	1/20	.38	.75	1.17	5	15
	460 KG	2.78	44.42	.3785						

* @ 70°/90°F (21°/32°C) based on total consumption for a split system.

¹ KWH rating is for a split system. Actual KWH for RLE connected to a rack system may be less.

MODEL	DIMENSIONS IN / CM			SHIPPING WEIGHT LBS KG	APPROX OPERATING CHARGE R-404A LBS / KG	REFRIGERATION REQUIRED*** BTU/HR / KCAL/HR
	W	D	H			
1000-RLE	21	28	30-1/2	295	1.5	9,500
	53	71	77	134	.68	2394

*** @ 0°F [-18°C] Evaporator Temperature

WARRANTY

See complete warranty for details.

- 25 year evaporator warranty
- 10 year ice blade warranty
- 2 year parts warranty

OPERATING PARAMETERS

	MINIMUM	OPTIMUM	MAXIMUM
AMBIENT TEMPERATURE	50°F (10°C)	90°F (32°C)	100°F (38°C)
WATER TEMPERATURE	45°F (8°C)	70°F (21°C)	90°F (32°C)
WATER PRESSURE	20 PSI	25-40 PSI	60 PSI