

# Rapid Freeze High Ambient Air Cooled

50 hz R-404A, R448A, R449A  
Condensing Units

**COOL SOLUTIONS SINCE 1912**

## HOWE Proven. Best Choice.

Howe's high ambient condensing units are sized and configured to match Howe Rapid Freeze ice flakers. These units are designed for unexcelled quality, reliability, and long life. They are durable, energy efficient and they provide a high degree of flexibility to a wide diversity of industrial applications.

### STANDARD FEATURES

- High efficiency Copeland scroll compressors with POE Oil.
- Thermally protected permanently lubricated ball bearing condenser fan motors.
- Electrical controls in weatherproof control box with compressor contactor and fused control circuit.
- Head pressure control system
- Suction & liquid vibration eliminators.
- Liquid line filter-drier and sight glass.

### SPECIAL FEATURES

- Pump down toggle switch
- Suction Accumulator
- Oil Separator with oil return line.
- Separate high pressure, low pressure control switches
- Oversized condensing units rated for 110°F ambient conditions.

### OPTIONAL FEATURES

- Coated condenser coils for harsh environments.



HA4002-A-R404A-1 shown.

## SIDE VIEW

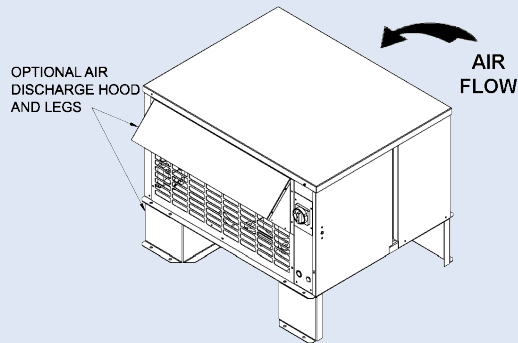

## END VIEW

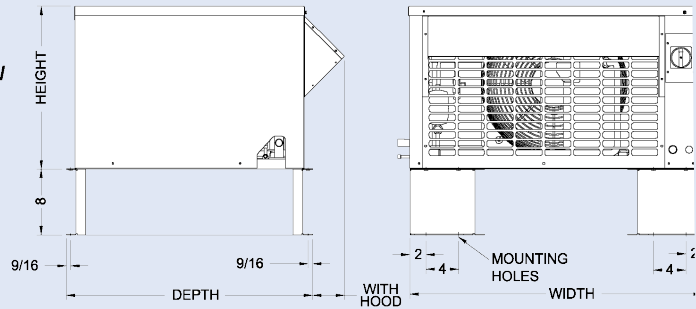

## CONDENSING UNIT

MODEL	DIMENSIONS			CM			CONDENSING UNIT CONNECTION SIZES		REQUIRED RUN LINE SIZES		SHIPPING WEIGHT		REC. CAP 90% LBS.
	IN W	D	H	W	D	H	SUCTION	LIQUID	SUCTION	LIQUID	LBS	KG	
HA1002-A-R4***-2	36-7/8	30-3/8	19-7/8	92.39	77.15	50.48	7/8	3/8	7/8	3/8	430	195	14
HA2002-A-R4***-2	43-7/8	32-7/8	30-7/8	111.44	83.5	78.42	1-1/8	1/2	1-1/8	1/2	485	220	22
HA3002-A-R4***-2	52-1/8	35-7/8	41-7/8	132.4	91.1	106.4	1-3/8	5/8	1-3/8	1/2	525	238	30
HA4002-A-R4***-2	65-1/8	35-7/8	41-7/8	165.4	91.1	106.4	1-3/8	5/8	1-3/8	1/2	745	338	54
HA6002-A-R4***-2	75-7/8	45-3/4	45-1/2	192.7	116.2	115.6	1-5/8	5/8	1-5/8	5/8	1185	538	76

\*\*\*= 04A for R-404A, 48A for R-448A, 49A for R-449A

## ELECTRICAL

VOLTAGE	MODEL	COMPRESSOR		CONDENSER FAN MOTORS			UNIT AMPS	MCA	MOP
		RLA	LRA	QNT.	WATT	FLA (EACH)			
380/3/50	HA1002-A-R4**A-2	5.7	46	1	240	.6	6.3	7.9	14.2
	HA2002-A-R4**A-2	8.9	74	1	400	1.1	10.0	12.4	22.4
	HA3002-A-R4**A-2	14.4	121.4	1	400	1.1	15.5	19.3	34.8
	HA4002-A-R4**A-2	19.3	118	2	800	2.1	23.5	29.4	52.9
	HA6002-A-R4**A-2	26.3	139	2	800	4.2	34.5	43.1	77.6

<sup>1</sup> = Receiver capacity is based on R404A refrigerant.

Multiply R404A value by the appropriate value below for alternate refrigerants:

R407A	R407C	R448A	R449A	R507	R22
1.10	1.10	1.05	1.05	1.0	1.15